

INSTRUCTIONS FOR Heavy-Duty Shelving Unit (#5248-01)

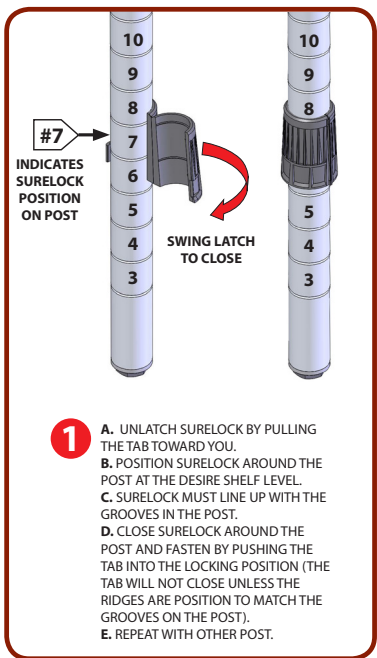

- A. UNLATCH SURELOCK BY PULLING THE TAB TOWARD YOU.
- B. POSITION SURELOCK AROUND THE POST AT THE DESIRE SHELF LEVEL.
- C. SURELOCK MUST LINE UP WITH THE GROOVES IN THE POST.
- D. CLOSE SURELOCK AROUND THE POST AND FASTEN BY PUSHING THE TAB INTO THE LOCKING POSITION (THE TAB WILL NOT CLOSE UNLESS THE RIDGES ARE POSITION TO MATCH THE GROOVES ON THE POST).
- E. REPEAT WITH OTHER POST.

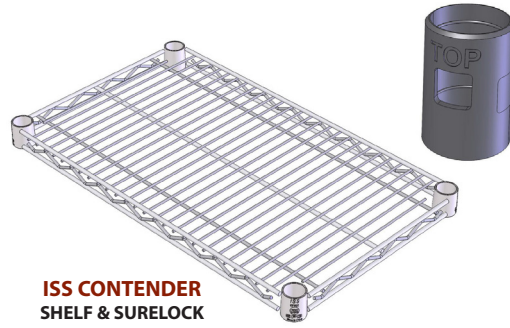
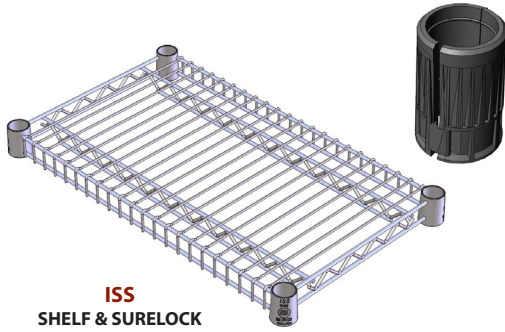
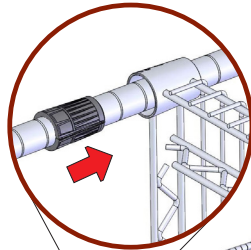

- 2**
- A. PLACE SHELF LENGTHWISE ON THE FLOOR.
 - B. WITH SURELOCK INSTALLED IN THE CORRECT POSITION ON EACH POST.
 - C. FIRMLY INSERT INTO EACH CORNER.

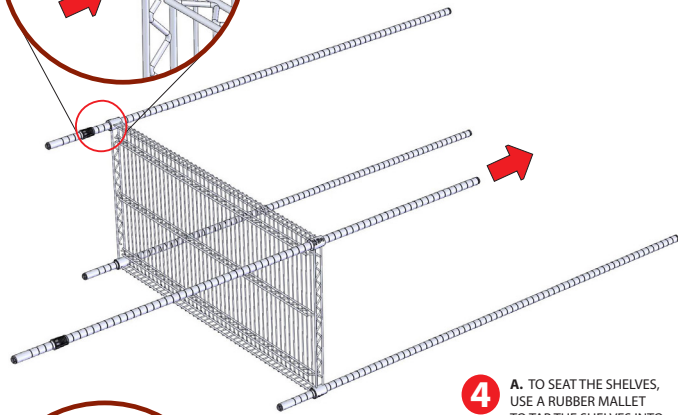

- 4**
- A. TO SEAT THE SHELVES, USE A RUBBER Mallet TO TAP THE SHELVES INTO PLACE. TAP THE FRONT EDGES NEAR THE CORNERS.

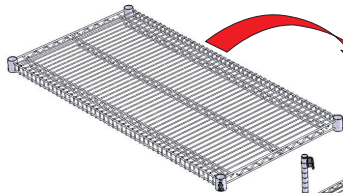
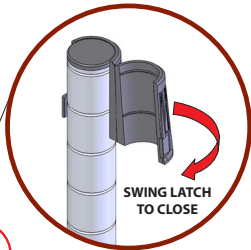

- 3**
- A. STAND FRAMES AND POST IN AN UPRIGHT POSITION AND FIRMLY PRESS DOWNWARD ON EACH CORNER.
 - B. SELECT HEIGHT OF NEXT SHELF AND REPEAT STEP 1.
 - C. CAREFULLY SLIP NEXT SHELF DOWN POSTS UNTIL ALL FOUR CORNERS ARE SECURE ON SURELOCK. PRESS FIRMLY DOWNWARD ON EACH CORNER.
 - D. REPEAT STEPS FOR ALL THE REMAINING SHELVES.

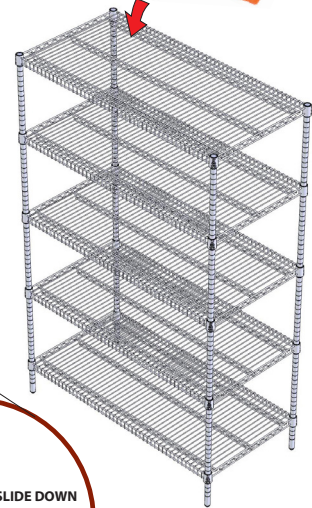
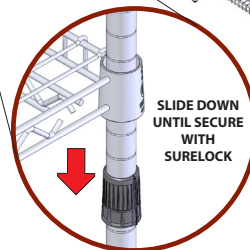
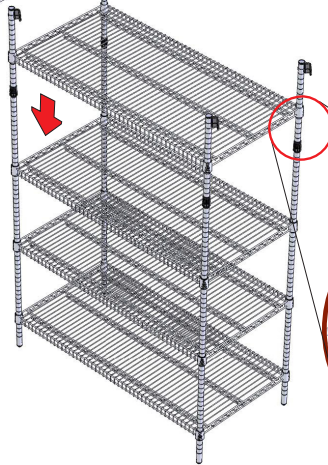

Call Free 1.800.848.1633 • Fax Free 1.800.447.2923
Web: GoHCL.com • Email: hcl@GoHCL.com